

**MAXLIGHT** | Projection  
Solutions

# MP SERIES MOTORISED UST PROJECTOR DRAW SLIDER



# Overview



## Packing List

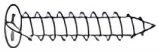

Self-taping Screw  
\*2



Draw Slider Fixing  
Plate Screw  
\*4



Upright Extension  
Plate screw  
\* 4

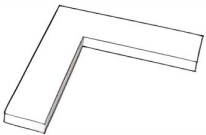

L-shaped Anti-Slip  
Foot Pads \* 4



Draw Slider Fixing Plate  
\* 2

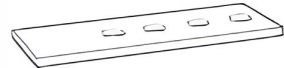

Extension Plate \* 2



AC Adapter \* 1



Smart Control Unit \* 1

## 1. Install the upright extension plate.

Choose the appropriate installation option according to the user scenario.

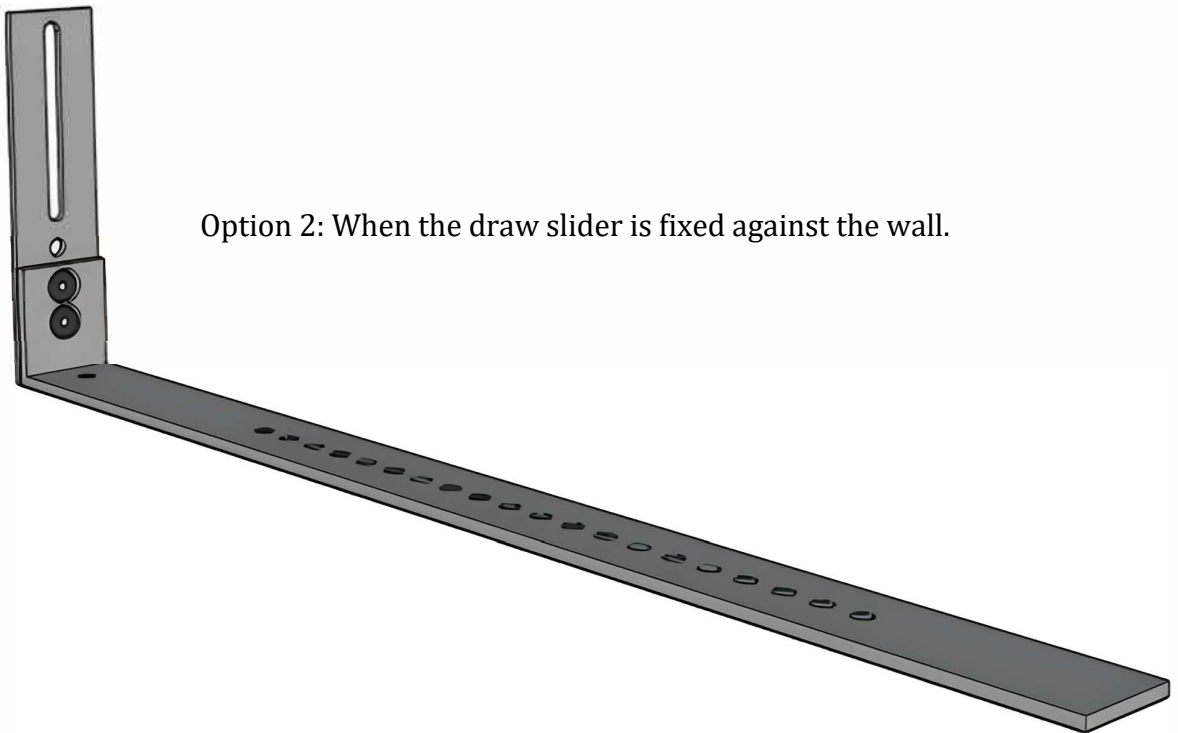
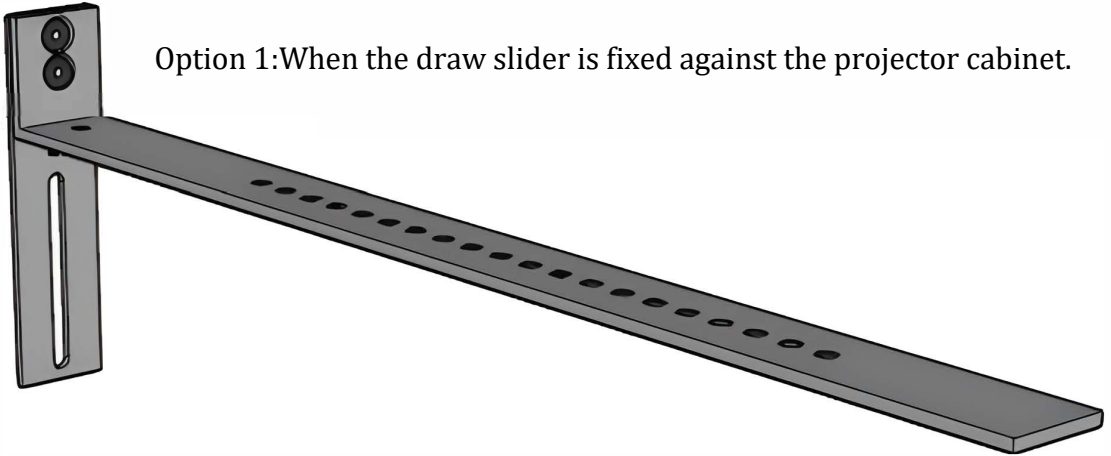

## 2. Install the draw slider fixing plate.

Measure the distance required between the wall/side of the projector cabinet. Turn the draw slider upside down, then install the fixing plate at the preferred position with four screws.

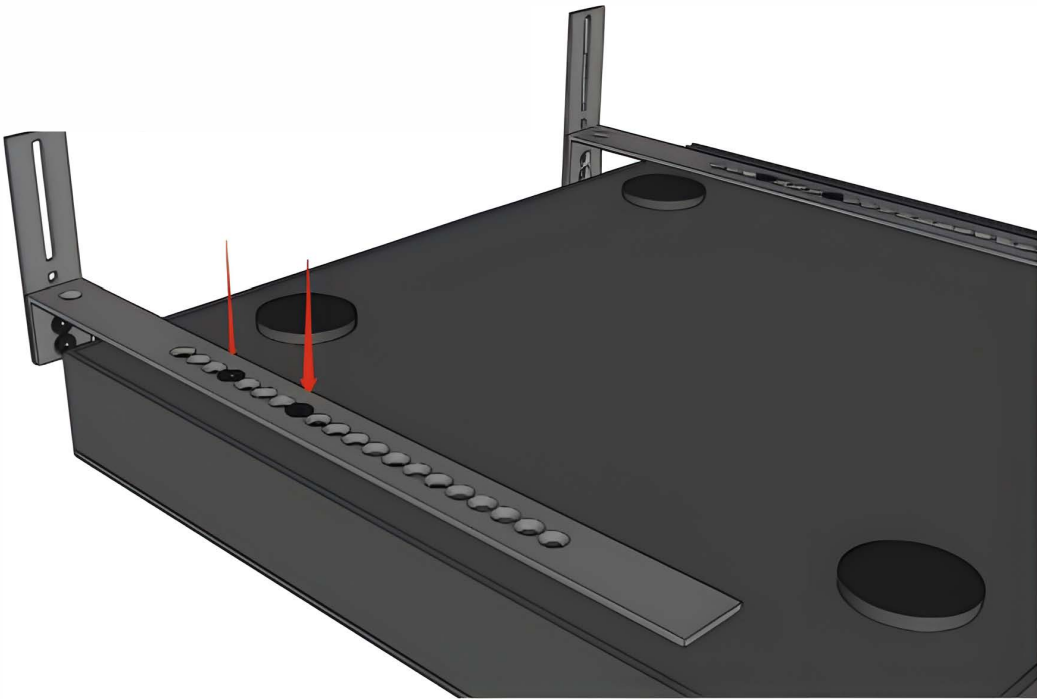

## 3. Install the draw slider:

**Scenario 1 - When the draw slider is fixed on the projector cabinet. Fix the extension plate on the back of the projector cabinet.**

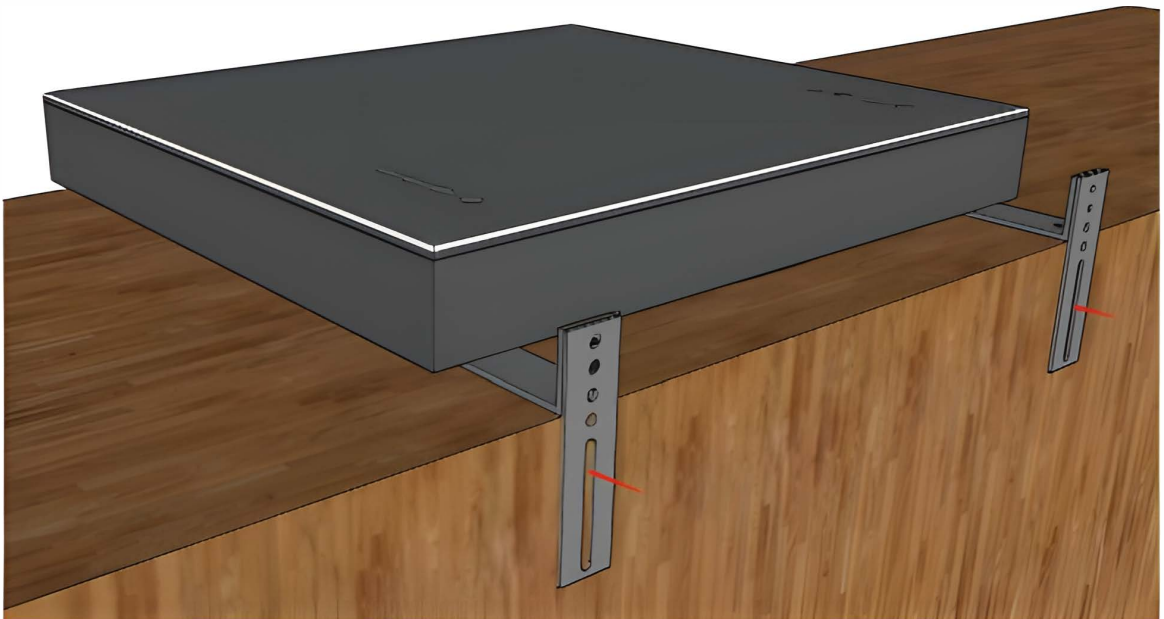

**Scenario 2 - When the draw slider is fixed against the wall. Fix the extension plate on the wall.**

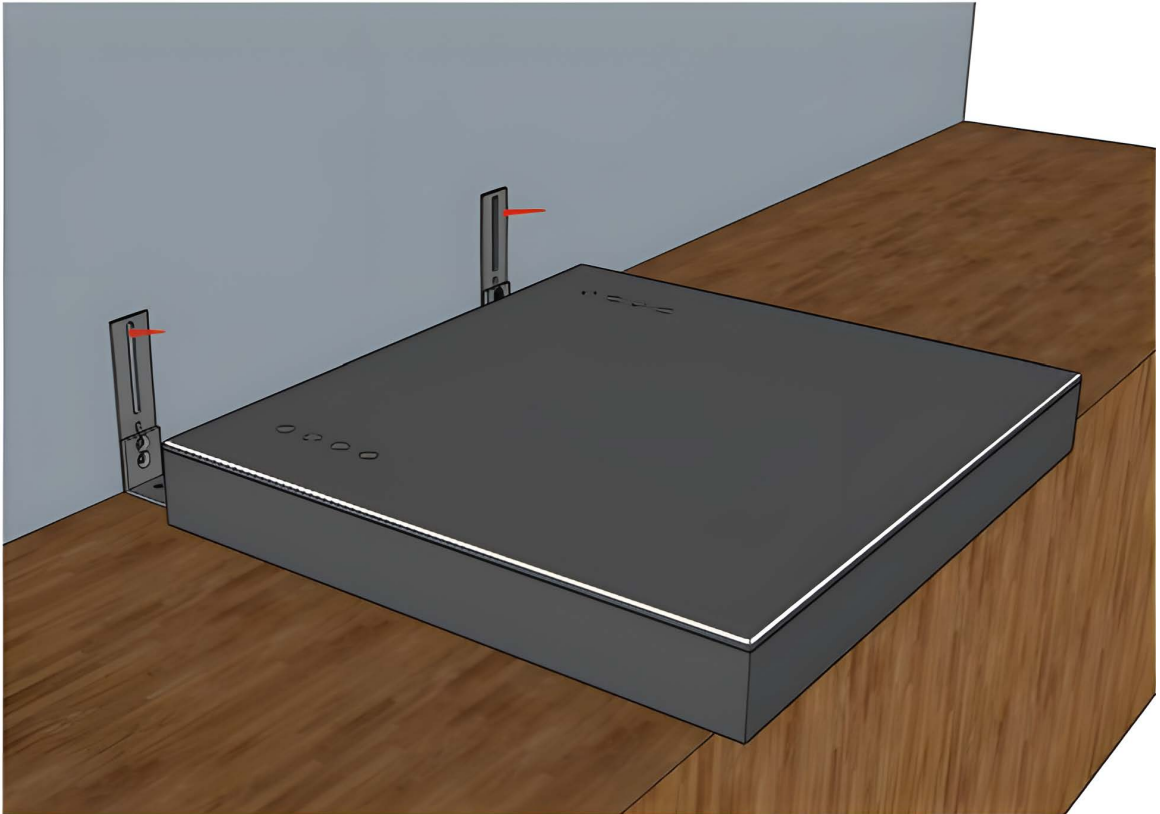

**Scenario 3 - Fix the draw slider directly on the projector cabinet without the extension plate.**

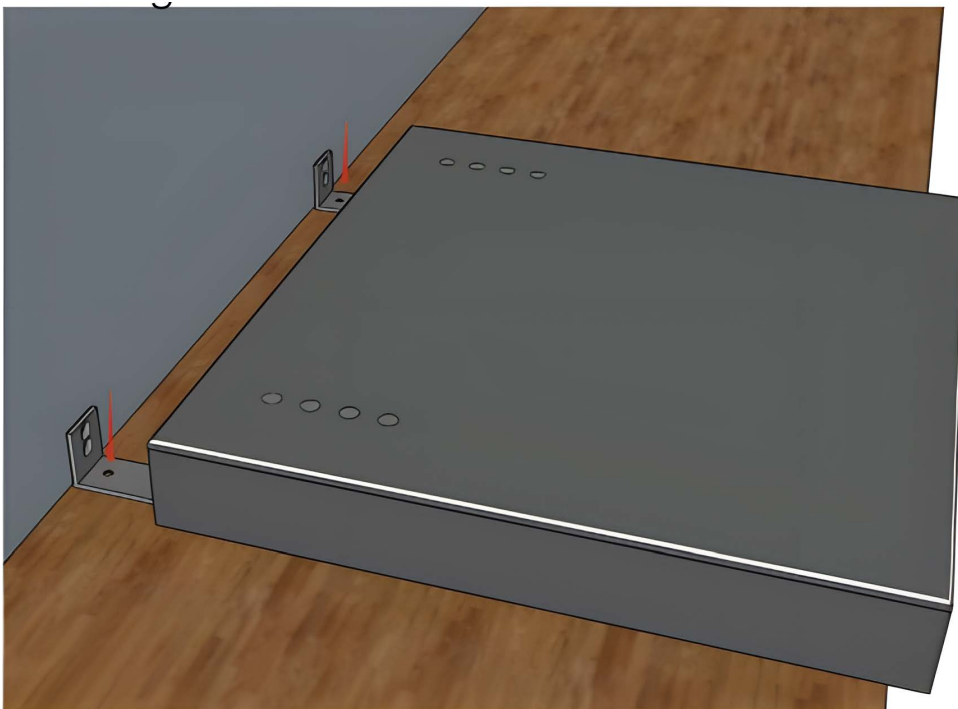

**Warning! The drawer slider should be fixed on the projector cabinet in all scenarios to avoid the risk of a sudden projector drop.**

#### 4. Install the L-Shaped anti-slip projector foot pads.

When the draw slider is installed and the image calibrated, install the four anti-slip projector feet to avoid unwanted projector movement.

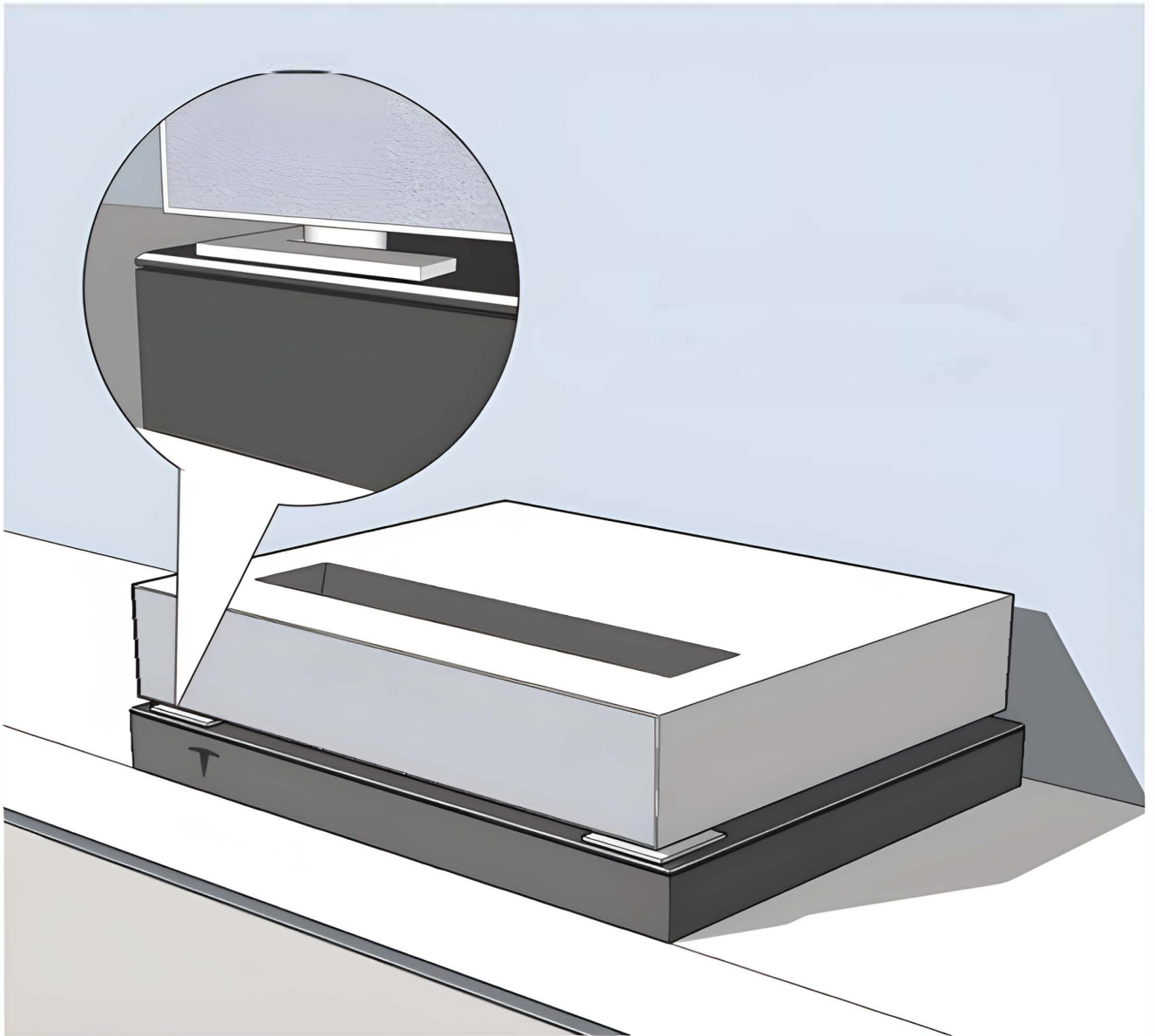

## 5. Smart Control Unit Instruction

Plug in the AC adapter and connect the AC adapter to the wall socket. Use the supplied plug adapter when necessary.

Plug the power cord of the projector into the smart control unit. Use the supplied plug adapter when necessary.

*Info: If necessary, an extension lead can be used to supply power to the draw slider and smart control unit.*



Use your smartphone to scan the QR code below to install the Perfectisan Device app. (available for iOS and Android).



**Turn on Bluetooth and location service on your smart phone.**

**Tap Search for Bluetooth device.**

**Tap to select the draw slider; it will pair the smartphone with the draw slider.**

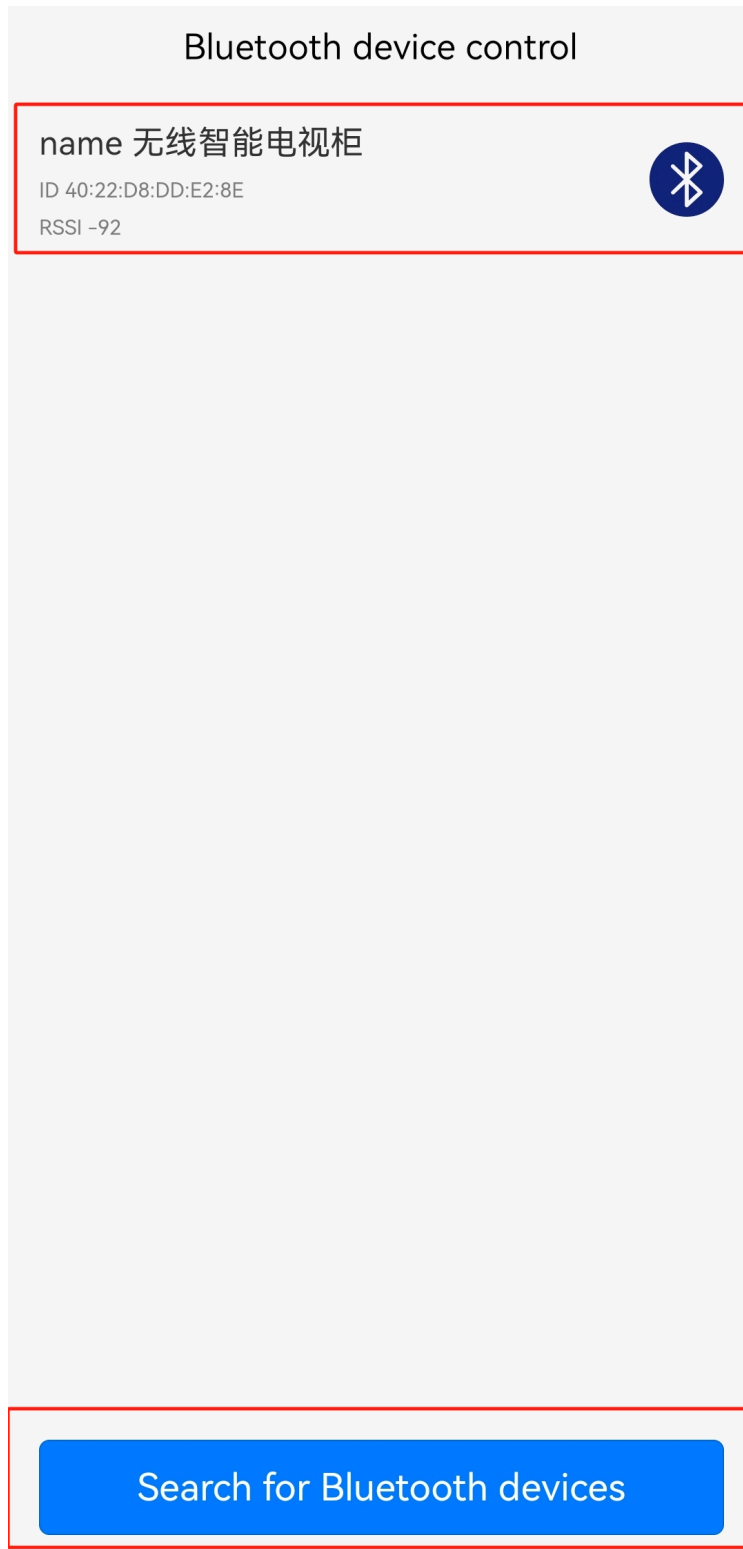



When Bluetooth pairing is completed, the control interface will be displayed.

To adjust the draw slider's trip distance, drag along the distance bar or tap on the trip+/- key.

The other keys on the app applied to the Maxlight UST projector cabinet; please ignore them.

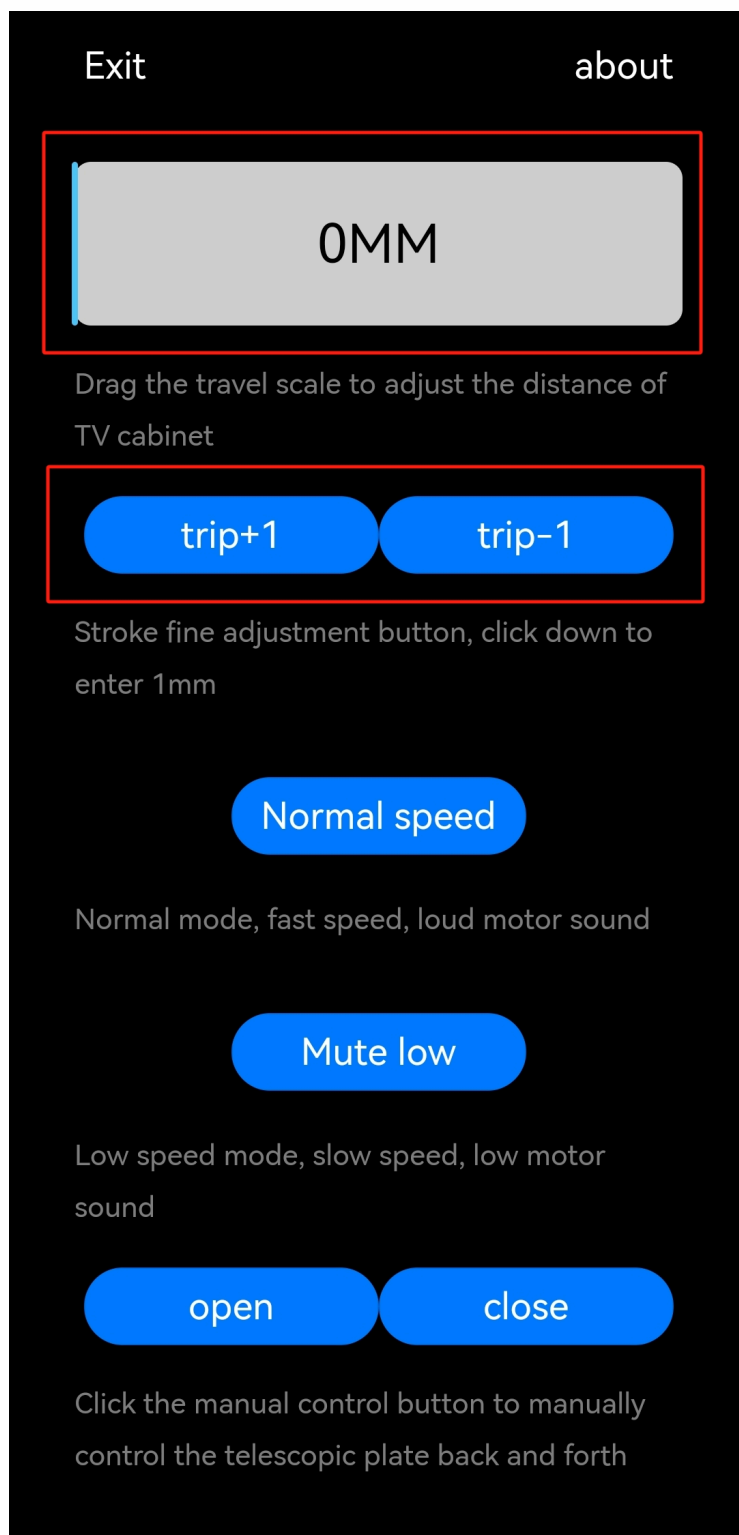

**MAXLIGHT** | Projection  
Solutions

